

TAILWHEELS

MAULE MODEL SFSA SOLID TAILWHEELS

The SFSA tailwheel assembly is of the same type construction as the SFS-P8A unit except for the tire, which is a 6.50 x 2.50 soft rubber solid tire. Spring connector kit not furnished with this model. FAA-approved. Wt. 6 lbs.

- SFSA-1-4, for 1-1/4" SpringP/N 06-16710**\$949.00**
- SFSA-1-2, for 1-1/2" SpringP/N 06-16720**\$949.00**
- Replacement Tire & BearingsP/N TW-23A**\$345.00**

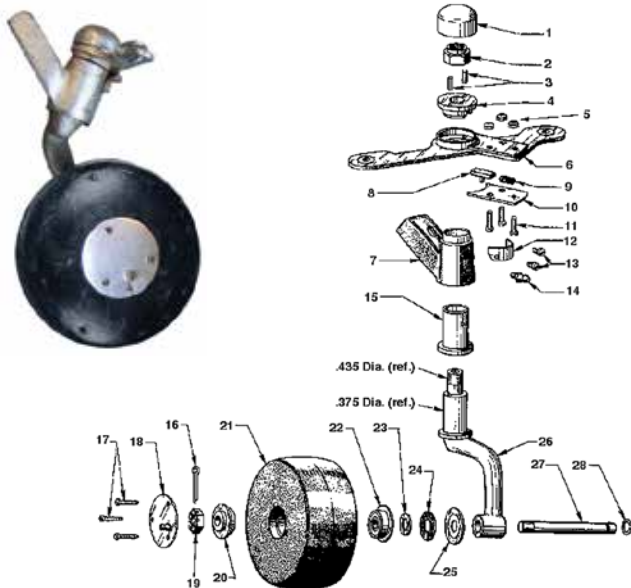

MAULE MODEL SFS-P8A PNEUMATIC TAILWHEELS

An inexpensive 8" pneumatic tailwheel assembly which is steerable and full swiveling, with new improved single arm shimmy-free fork. All working parts heat treated. FAA approved. Wt. 7 lbs.

- Maule Tailwheel #SFS-P8A-1-4*P/N 06-16730**\$959.00**
 - Maule Tailwheel #SFS-P8A-1-2**P/N 06-16740**\$916.00**
 - Specialty Tire 2.80/2.50-4 4 PlyP/N 06-08000**\$76.75**
 - Specialty Tube 280 X 250 X 4P/N 06-08101**\$38.50**
- * - For 1-1/4" Leafspring ** - For 1-1/2" Leafspring

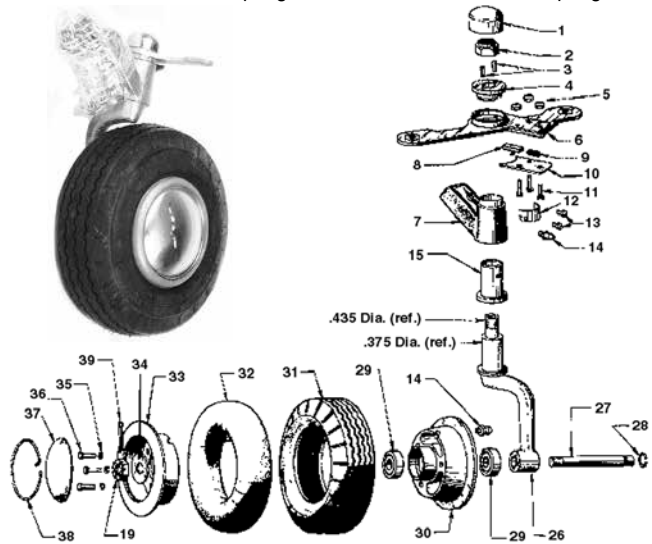

LG

MAULE P8B TUNDRA TAILWHEEL

A new tailwheel with 8" pneumatic tire designed and engineered to meet the toughest conditions on all types of airports and landing fields.

- SFS-P8B-1-4 For 1-1/4" Leaf Spring WidthP/N 06-16750**\$982.00**
- SFS-P8B-1-2 For 1-1/2" Leaf Spring WidthP/N 06-16760**\$982.00**
- SFS-P8B-3-4 For 1-3/4" Leaf Spring WidthP/N 06-16770**\$1,010.00**

MAULE TAILWHEEL PARTS LIST

#	Description	Old Style (Pre 1976) has 3/4" Fork Shaft & New Style (Post 1976) has 7/8" Fork Shaft		Qty. Req.	Price Each
		Old Style SFS-P8 Pneumatic or SFS Solid Rubber	New Style SFS-P8A Pneumatic and SFSA Solid Rubber		
1	Cover Cap	TW-18 (1-1/4")	TW-63A (1-3/8")	1	\$15.50
2	Nut	AN364-720A or AN365-720	AN364-720A or AN365-720	1	\$1.68
3	Lock Ring Pin	TW-17	TW-60AB	1/2	\$11.55
4	Lock Ring	TW-16	TW-57	1	\$49.85
5	Nut	AN364-440A	AN364-440A	3	\$0.44
6	Steering Arm Assembly*	TW-15 (TW-13 & TW-16 are included in this Assembly)		1	\$225.95
7	Bracket Assembly, 1-1/4"	06-16101	06-16201	1	\$233.95
7	Bracket Assembly, 1-1/2"	06-16102	06-16202	1	\$212.95
8	Lock Pin	TW-13	TW-13	1	\$37.50
9	Steering Arm Spring	TW-14	TW-14	1	\$7.35
10	Lock Cover Plate	TW-12	TW-12	1	\$16.50
11	Screw	MS35206-217	MS35206-217	3	\$0.06
12	Cam	TW-10	TW-10	1	\$42.50
13	Screw	AN501-A10-4	AN501-A10-4	2	\$0.38
		AN520-10-4	AN520-10-4		
14	Zerk Fitting	TW-7-A14	TW-7-A14	1	-----
15	Oilite Bearing	TW-7 (3/4" I.D.)	TW-59A (7/8" I.D.)	1	\$33.50
Items 16 through 25 are for the solid rubber tire assembly only.					
16	Cotter Pin	AN380-3-3	AN380-3-3	1	\$0.14
17	Screw	TW-A18	TW-A18	3	\$0.15
18	Hub Cap	TW-27	TW-27	1	\$25.50
19	Axle Nut	AN320-8	AN320-8	1	\$2.27
20	Bearing	TW-3	TW-3/A15	1	\$41.85
21	Tire—solid, no bearings	TW-23	TW-23	1	\$297.00
21	Tire—solid, with bearings	TW-23A	TW-23A	1	\$345.00

#	Description	Old Style (Pre 1976) has 3/4" Fork Shaft & New Style (Post 1976) has 7/8" Fork Shaft		Qty. Req.	Price Each
		Old Style SFS-P8 Pneumatic or SFS Solid Rubber	New Style SFS-P8A Pneumatic and SFSA Solid Rubber		
22	Bearing (with washer)	TW-A15	TW-A15	1	\$41.85
23	Washer	TW-28	TW-28	1	\$2.35
24	Felt Seal	TW-26	TW-26	1	\$2.75
25	Retainer Washer Fork (with axle)	TW-64	TW-64	1	\$6.95
27	Axle	TW-5	TW-5	1	\$72.80
28	Axle Sircilip Ring	TW-6	TW-6	1	\$6.95
29	Bearing	TW-A7	TW-A7	2	\$166.95
30	Inboard Wheelhalf, with bearings	TW-30	TW-30	1	\$394.00
31	Tire, 8-inch			1	-----
32	Tube			1	-----
33	Outboard Wheelhalf	TW-31	TW-31	1	\$179.85
34	Washer	TW-A6	TW-A6	1	\$1.40
35	Lock Washer	AN935-516	AN935-516	3	\$0.07
36	Bolt	TW-A12	TW-A12	3	-----
37	Hub Cap	TW-32	TW-32	1	\$46.50
38	Hub Cap Sircilip Ring	TW-33	TW-33	1	\$4.35
39	Cotter Pin	AN380-3-3	AN380-3-3	1	\$0.14
Items 40 through 44 are used on the "Old" style & pneumatic tailwheel that have a shimmy dampener.					
40	Adjusting Screw	TW-40		1	-----
41	Dampener Spring	TW-41		1	-----
42	Friction Block	TW-42		1	-----
43	Hex Housing	TW-43		1	-----
44	Bracket Assembly, 1-1/4 inch drilled	TW-44-1-4		1	-----
	Bracket Assembly, 1-1/2 inch drilled	TW-44-1-21			-----

MAULE ARM ASSEMBLIES

Fig. No.	Description	Style	Qty Req.	Part No.	Price
26	Arm Assembly .375 Dia. (Pneumatic)	Old	1	TW-58A	\$159.75
26	Arm Assembly without Axle .435 Dia. (Solid Rubber)	New	1	TW-61A	\$239.25
26	Arm Assembly with Axle .435 Dia. (Solid Rubber)	New	1	TW-61A	\$239.25
26	Arm Assembly .375 Dia. (Pneumatic)	New	1	TW-58A-1	\$206.75
26	Arm Assembly .375 Dia. (Solid Rubber)	Old	1	TW-21-1	---